



An Android Based Patient Monitoring System

Gowthami.P

*Department of Medical Electronics engineering
Sengunthar college of engineering
Namakkal, Tamilnadu, India.*

Dr.P.Sathishkumar

*Principal, Sengunthar college of engineering
Namakkal, Tamilnadu, India.*

Abstract—This paper proposes an efficient online patient monitoring using android application. Telemedicine is a rapidly developing application of clinic medicine where medical information is transferred through the phone or internet or other networks for the purpose of consulting and performing remote medical procedures or examinations. Telemedicine can be applied to a greater extent in the field of patient monitoring serves as the major tool. This project elaborates the experience; a methodology adopted and highlights various design aspects to be considered for making telemedicine in patient monitoring system effective. In this method, the patient's vital signs like heart rate, blood pressure, temperature, Angle Displacement Measurement, object reflection measurements are captured and the values are entered into the database. It is then uploaded into the web based server and sent to the doctor's phone using ANDROID technology.

Keywords—Android, Patient monitoring, Telemedicine, Database

I. INTRODUCTION

A Patient Monitor (also known as Vital Signs Monitors) are a medical monitor or physiological monitor or display, is an electronic medical device that measures a patient's vital signs and displays the data so obtained, which may or may not be transmitted on a monitoring network. Physiological data are displayed continuously on a CRT or LCD screen as data channels along the time axis, They may be accompanied by numerical readouts of computed parameters on the original data, such as maximum, minimum and average values, pulse and respiratory frequencies, and so on. In critical care units of hospitals, bedside units allow continuous monitoring of a patient, with medical staff being continuously informed of the changes in general condition of a patient. Some monitors can even warn of pending fatal cardiac conditions before visible signs are noticeable to clinical staff, such as atrial fibrillation or premature ventricular contraction (PVC).

II. NEEDS AND SCOPE OF THIS PROJECT

Patient monitoring system is a process where a surgeon can continuously monitor more than one patient, for more than one parameter at a time in a remote place. With the development of Smart-phone, it has performed a Smartphone based body monitoring system with a combination of the advantages of network technology and multiple sensor fusion technology. Body monitoring system greatly improves the operational capability of health care, such as remote operations, wireless health care so on. There has been a growing concern with technology of medical care which has developed rapidly and plays an increasingly important role in our life.

The modern visionary of healthcare industry is to provide better healthcare to people anytime and anywhere in the world in a more economic and patient friendly manner. Therefore for increasing the patient care efficiency, there arises a need to improve the patient monitoring devices and make them more mobile. The medical world today faces two basic problems when it comes to patient monitoring. Firstly, the needs of health care's provider's presence near the bedside of the patient and secondly, the patient is restricted to bed and wired to large machines. In order to achieve better quality patient care, the above cited problems have to be solved.

As the bio instrumentation, computers and telecommunications technologies are advancing, it has become feasible to design more portal vital sign tele-monitoring systems to acquire, record, display and to transmit the physiological signal from the human body to any location. Recent works in communication technologies have inspired the development of telemedicine to a large extent. Telemedicine benefits not only the customers who are able to receive health care more efficiently; it also benefits the doctors who can streamline their efforts to assist more patients.

The advances in information and communication technologies enable technically, the continuous monitoring of health related parameters with wireless sensor, wherever the user happens to be. They provide valuable real time information enabling the physicians to monitor and analyze a patient's current and previous state of health.

Now days there are several efforts towards the development of system that carry out remote monitoring of patients. Although many wireless standards can be used, there are important considerations such as range, throughput, security, ease of implementation and cost. The patient monitoring involves handling of sensitive data. These data should be transmitted securely without any intrusion.

The web-database is a system where the web server will store the data in table format where the digital data are filled in column and then it is plotted against the time to get the parameters. For GUI, Android is used, since its open source and very cheaply available in market which fulfils the criteria of low cost system. Also now days, Android is available to each and every person, including Doctors, since they have started using the Smartphone. In present paper, we report on development of patient monitoring system an android platform which is an open source, to display five parameters such as Heart Beat, Temperature, Blood Pressure, Bone flexibility and Drowsiness. With this module, the doctors who are not present in hospital at time of emergency, they can also operate looking at the different parameters on his or her smart phone or laptop.

III. SYSTEM DESCRIPTION

Our aim is to develop patient monitoring system which has telemetry included in that system. The system also includes the web server and web database system from where the data of patient is transmitted all over the world. The block diagram of proposed system is shown in figure.

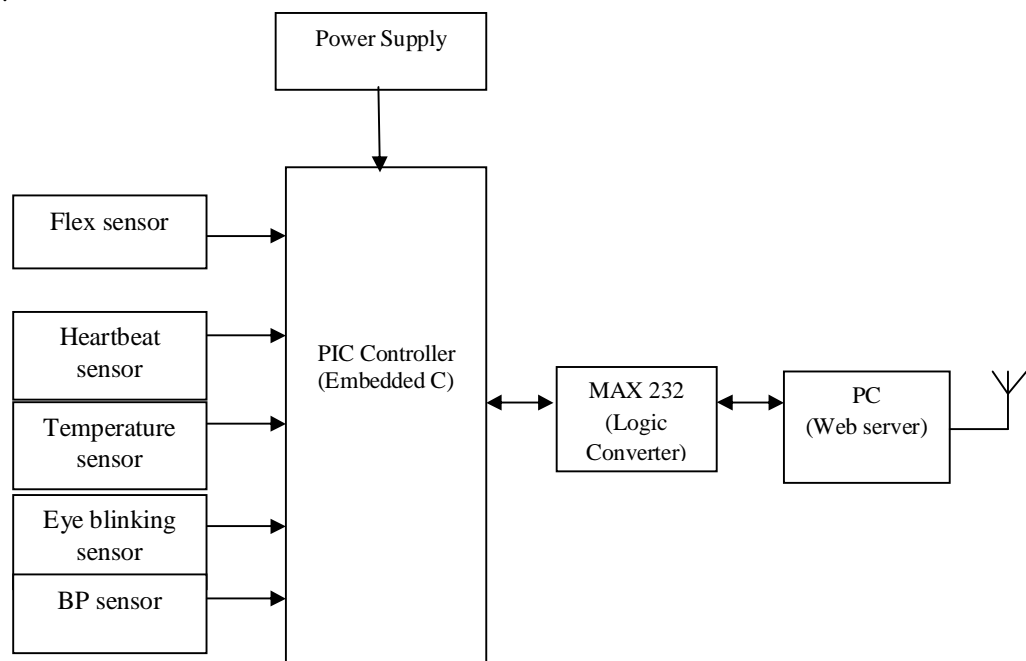

Fig. 3.1 Block diagram of the project

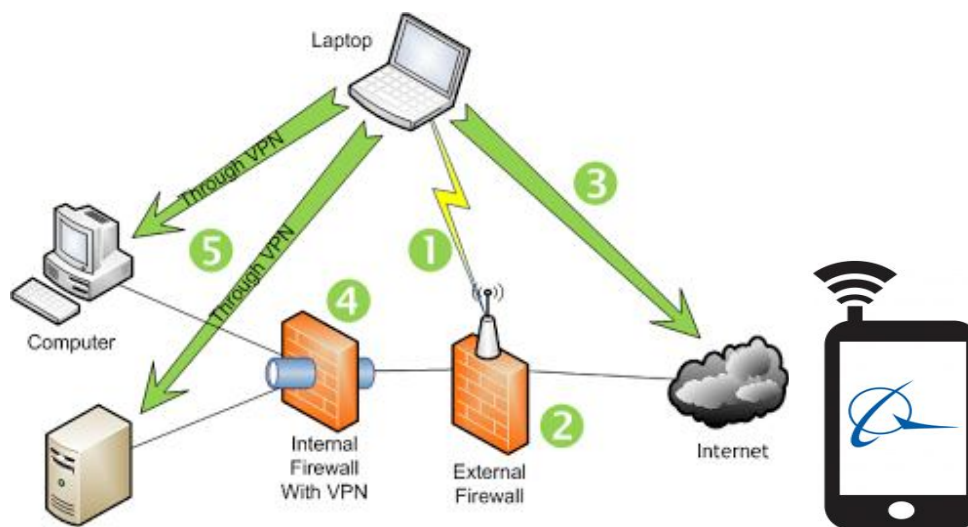

Fig. 3.2 Functional diagram of the project

The block diagram consists of Hardware and Software. This system helps the doctor to work from outside of hospital premises. The hardware consists of 3 blocks sensors, microcontroller and display system. Since its patient monitoring system, multiple parameters are acquired and for proper signal acquisition, the placement of electrodes is utmost important factor. Thus placing the electrodes on the body for acquiring the different signal at a time is a main task. After acquiring the data from the sensor, it is amplified since the bio-signals have very low amplitude in micro-volts. So for proper diagnostic bio-amplifier is used which will amplify the signal and display it on display system.

IV. RESULTS

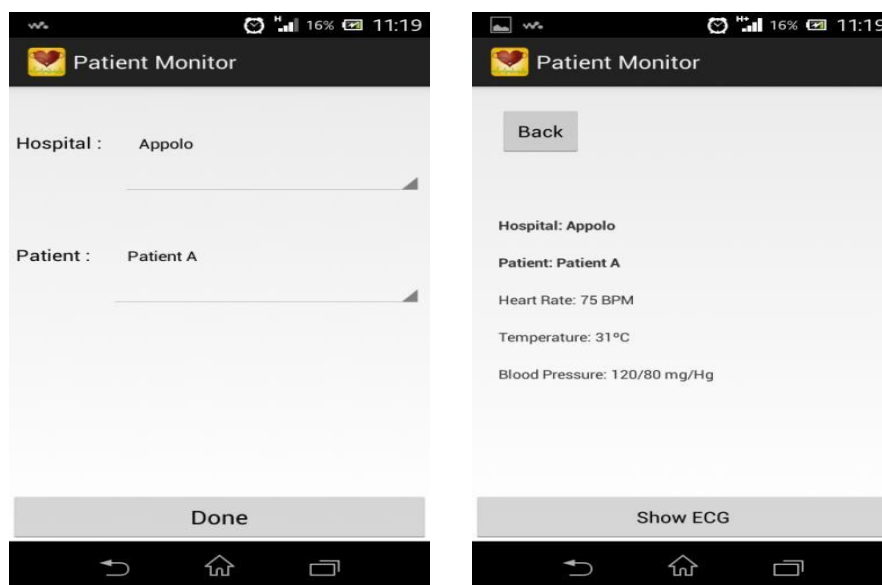

Fig. 4. GUI for Doctor-Login and Doctor-Informative Page



V. ACKNOWLEDGMENT

I wish to express my profound thanks to Medical Electronics engineering department, Sengunthar college of engineering, trichengode and faculty members for providing me all the facilities in making this project possible.

REFERENCES

- [1].P.Karthick , C.Sureshkumar , P.Arunprasad, S.Pusparaj , M.Jagadeeshraja , N.Suthanthira vanitha , ‘Embedded based real-time patient monitoring system, international journal of VLSI and Embedded systems’, ISSN:2249 – 6556, pp. 773 -777, 2014.
- [2].A.J. Burns and M. Eric Johnson, ‘Securing health information’, Published by the IEEE Computer Society, pp. 23-29, 2015.
- [3].Paulj. F. White, Blake W. Podaima, and Marcia R. Friesen, ‘Algorithms for Smartphone and Tablet Image Analysis for Healthcare Applications’, the journal for rapid open access publishing, vol 2, pp. 831-840, 2014.
- [4].Péter Várady, Zoltán Benyó, and Balázs Benyó, ‘An Open Architecture Patient Monitoring System Using Standard Technologies’, IEEE Transactions on information technology in biomedicine, vol. 6, no. 1., pp. 95 – 98, 2002.
- [5].Zaosheng Zhang, and TingLei Huang, ‘An Intelligent Patient Monitoring System for Home Application’, Genetic and Evolutionary Computing, pp. 389 – 392, 2009.